

Rigid Haul Truck

| | |
|----------------------------------|---|
| MAX. GROSS VEHICLE WEIGHT | 171,870 lbs (77,960 kg) |
| NET ENGINE POWER | 495 hp (370 kW) |
| MAX. PAYLOAD | 45 Tons (41 t) |
| HEAPED CAPACITY | 34 Yd ³ (26 m ³) |

Specifications
Frame

Full box section frame rails, integral front bumper, closed-loop crossmember and torque tubes of 42,000 lbf/in² (290 MPa) yield strength steel. Cross member connections are 95,000 lbf/in² (655 MPa) steel castings.

Engine

| | |
|---|--------------------------------|
| Make / Model | Cummins QSK19-C525 |
| Type | 4 cycle, turbocharged / CAC |
| Gross power @ 2,100 rpm (SAE J1995) | 525 hp (392 kW) |
| Net power @ 2,100 rpm | 495 hp (370 kW) |
| Engine emission meets Tier III USA EPA/CARB MOH 40 CFR 89 and EU non-road mobile machinery directive. Stage 3. | |
| Maximum torque @ 1,300 rpm | 1,775 lbf ft (2,441 Nm) |
| Cylinders/Configuration | 6 in line |
| Bore x stroke | 6.25 x 6.25 in (159 x 159 mm) |
| Displacement | 1,150 in ³ (18.9 L) |
| 24 volt negative ground electrical system. Two 12 volt 165 Ah batteries with master disconnect switch. 8.9 kW starter. Neutral start. 70A alternator with integral voltage regulator. | |

Transmission

Allison M5610AR automatic electronic control with Soft Shift feature. Mounted mid-frame for ease of access. Integral torque converter and planetary gearing. Six speeds forward, two reverse. Automatic lock-up in all speed ranges. Downshift inhibitor. Hydraulic retarder.

| Gear | Forward | | | | | | Reverse | |
|-------|---------|------|------|------|------|------|---------|------|
| | 1st | 2nd | 3rd | 4th | 5th | 6th | R1 | R2 |
| Ratio | 4.00 | 2.68 | 2.01 | 1.35 | 1.00 | 0.67 | 5.12 | 3.46 |
| mph | 7.0 | 10.5 | 13.9 | 20.8 | 28.1 | 40.4 | 4.4 | 8.0 |
| km/h | 11.3 | 16.8 | 22.4 | 33.4 | 45.2 | 65.0 | 7.1 | 12.9 |

Suspension

Front: Terex manufactured kingpin strut-type independent front wheel suspension using self-contained, variable rate, nitrogen/oil cylinders.

Rear: Terex variable rate nitrogen/oil cylinders with A-frame linkage and lateral stabilizer bar.

| | |
|-------------------------------|-----------------|
| Maximum strut stroke: | |
| Front | 9.9 in (251 mm) |
| Rear | 7.2 in (182 mm) |
| Maximum rear axle oscillation | ± 6.5 Degrees |

Specifications

| Drive Axle | | |
|---|----------|----------|
| Terex heavy duty axle with single reduction spiral bevel gear differential, full floating axle shafts, and planetary reduction at each wheel. | | |
| Ratios: | Standard | Optional |
| Differential | 3.15:1 | 3.73:1 |
| Planetary | 5.66:1 | 5.66:1 |
| Total Reduction | 17.83:1 | 21.11:1 |

| Tires | | |
|--|-------------------|---------------|
| Standard: Front and rear | 21.00-35 bias ply | rim width 15" |
| Consult tire manufacturers for optimum tire selection and correct ton-mile/h (t-km/h) capacity for application. Tires subject to availability. | | |

| Brakes | | |
|---|--------------------------|---|
| SERVICE – All hydraulic brake system. Transmission mounted pressure compensating piston pump provides hydraulic pressure for brakes and steering. Independent circuits front and rear. Each circuit incorporates a nitrogen/hydraulic accumulator which stores energy to provide consistent braking response. | | |
| Front: | Dry disc, diameter | 26 in (660 mm) |
| | Swept area, front, total | 928 in ² (5 985 cm ²) |
| | Pad area, total | 216 in ² (1 395 cm ²) |
| Rear: Terex multi-plate oil-immersed brakes continuously cooled by oil flow supplied by a tandem pump on engine power take-off, and passing through a high capacity oil/water heat exchanger. Brake packs are sealed from contamination and are self adjusting. | | |
| Friction discs | | 14 total |
| Diameter | | 25.5 in (648 mm) |
| Braking Surface, total | | 5,938 in ² (38,310 cm ²) |
| Cooling flow, maximum | | 146 gpm (553 Lpm) |
| PARKING – Application of rear brakes by springs in brake disc pack. Hydraulically released. | | |
| RETARDATION – Modulated lever control of rear disc brakes or hydraulic retarder in transmission. 700 hp (522 kW) continuous. | | |
| SECONDARY BRAKE SYSTEM – Push button solenoid control applies service and parking brakes. Automatically applies when engine is switched off. Parking brake applies should system pressure fall below a pre-determined level. | | |
| Brakes conform to ISO 3450, SAE J1473 Oct 90 | | |

| Steering | |
|--|-----|
| Independent hydrostatic steering with closed-center steering valve, accumulator and pressure compensating piston pump. | |
| Accumulator provides uniform steering regardless of engine speed. In the event of loss of engine power it provides steering of approximately two lock-to-lock turns. A low pressure indicator light warns of system pressure below 1,200 psi (83 bar). Steering conforms to ISO 5010, (SAE J53). | |
| Maximum Tire Steering Angle | 39° |

| Hoist | |
|---|-------------------------------------|
| Two body hoist cylinders are mounted between the frame rails. Cylinders are two-stage with power down in the second stage. The body hydraulic system is independent of the steering hydraulic system. | |
| System relief pressure | 2,750 lbf/in ² (190 bar) |
| Body hydraulic pump flow rate @ 2,100 rpm engine speed | 60 gpm (227 Lpm) |
| Body raise / lower time | 13 seconds / 9 seconds |

| Body | | |
|--|------------------|---|
| Longitudinal 'V' type floor with integral transverse box-section stiffeners. The body is exhaust heated and rests on resilient impact absorption pads. Full time exhaust is optional. Body wear surfaces are high hardness (360-440BHN) abrasion resistant steel of yield strength 145,000 lbf/in ² (1,000 MPa) | | |
| Thickness: | Floor | 0.75 in (19 mm) |
| | Side | 0.39 in (10 mm) |
| | Front, lower | 0.39 in (10 mm) |
| ROPS cab guard SAE J1040 Feb 86. ISO 3471 | | |
| Volumes: | Struck (SAE) | 25.6 yd ³ (19.6 m ³) |
| | Heaped 2:1 (SAE) | 34.0 yd ³ (26.0 m ³) |

| Service Capacities | | |
|---|-----------|-----------|
| Engine crankcase and filters | 16.4 gal | (62.0 L) |
| Transmission and filters | 18.0 gal | (68.0 L) |
| Cooling system | 38.0 gal | (144.0 L) |
| Fuel tank | 160.0 gal | (606.0 L) |
| Steering hydraulic tank | 16.0 gal | (61.0 L) |
| Steering hydraulic system (total) | 22.5 gal | (85.0 L) |
| Body hydraulic tank | 57.0 gal | (216.0 L) |
| Body hydraulic and brake cooling system | 97.0 gal | (368.0 L) |
| Planetaries (total) | 17.4 gal | (66.0 L) |
| Differential | 15.8 gal | (60.0 L) |
| Front ride strut (each) | 3.7 gal | (14.0 L) |
| Rear ride strut (each) | 4.5 gal | (17.0 L) |
| Power take off | 1.0 gal | (4.0 L) |

Standard Equipment

CAB

Acoustic lining
Air conditioner R 134A 18,500 BTU/hr (5.4 kW)
Armrest, operators door
Door locks
Floor mat
FOPS protection (ISO 3449/SAE J 231)
Heater and defroster (10.3 kW - 35,000 BTU/hr)
Interior light/courtesy light
Mug holder
Radio/cassette player
ROPS protection (body cabguard) (ISO 3471/SAE J1040)
Air suspension seat with high back, headrest and 4-point harness
Seat, passenger
Seat belts SAE J386
Steering column, adjustable
Sun visor, full cab width
Tinted glass
Utility compartment
Window, electric - operators door
Windshield wipers - 2 speed and washers

CONTROLS

Battery isolator
Auto transmission shift
Transmission test button
Power/economy key switch
Manual mode key switch

GAUGES

Converter temp
Engine coolant temp
Engine oil pressure
Fuel
Speedometer/odometer
Tach/hourmeter
Transmission oil pressure

INDICATOR LIGHTS & ALARM

Brake pressure, front
Brake pressure, rear
Steering pressure
Steering/brakes oil level
Transmission "do not shift"

INDICATOR LIGHTS ONLY

Air cleaner restriction
Alternator not charging
Body up
Brake oil temp
Converter drive
Coolant level
Coolant temp
Direction indicators
Engine oil pressure
Headlamps, main beam
Parking brake on
Retarder on
Steering filter restriction
Transmission "check"
Transmission filter restriction
Transmission manual mode
Transmission oil temperature
Warning light test

GENERAL

Accumulator steering
Air cleaners (2), two stage
Automatic transmission
Body down signal
Body heating, exhaust
Body hoist, servo actuated
Coolant filter
Diagnostic pressure test points
Downshift inhibitor
Dual brake system
Electric start
Engine management system
Engine pan guard
Exhaust muffler (body up)
Exhaust muffler, part time
Fuel sight gauge
Headlights - quartz halogen (4)
Horn, dual electric, 117db (SAE J 1105)
Mud flaps
Nitrogen inflated tires
Operator arm guard
Parking brake (all wheels)
Rear view mirrors - 4
Transmission retarder or oil-cooled rear disc brakes
Retarder light - amber, rear
Reverse alarm
Reversing light- quartz halogen

| | |
|--|--|
| Rock ejectors | Shed plates, rear tires |
| Secondary brake system (all wheels) | Side, tail, stop, direction indicators and hazard warning lights |
| Security kit | Tow points, front and rear |
| Separate steering and body hoist hydraulic systems | Transmission guard |

Optional Equipment

GENERAL

Automatic lubrication
Beacon, flashing amber
Body, heavy duty
Body wear plates (floor, end, side and front protection)
Body, 40-ton (36.3t) payload
Cold start kit
Differential, no spin
Differential 3.73:1
Engine pre-lube starter
Exhaust muffler, full-time
Fan clutch
Fast fuel adapter

Fire extinguisher
Fire suppression system
Flashing strobe reverse light
Front brake pressure reduction selector
Front brake pressure reduction sensor
Oil drain kit, engine and transmission sumps
On-board weighing system
Spillguard extension, folding
Tachograph
Television monitor, rear view
Tool kit, hand

Weights

| | | |
|------------------------------|--------------------|--------------------|
| Chassis with hoists | 61,365 lbs | (27,835 kg) |
| Body, standard | 20,500 lbs | (9,300 kg) |
| Net Weight | 81,870 lbs | (37,135 kg) |
| Payload, maximum | 90,000 lbs | (40,825 kg) |
| Maximum Gross Weight* | 171,870 lbs | (77,960 kg) |

FOR UNIT EQUIPPED WITH OPTIONAL HEAVY DUTY BODY:

| | | |
|------------------------------|--------------------|--------------------|
| Chassis, with hoists | 61,365 lbs | (27,835 kg) |
| Body, heavy duty | 23,810 lbs | (10,800 kg) |
| Net Weight | 85,175 lbs | (38,635 kg) |
| Payload, maximum | 86,695 lbs | (39,325 kg) |
| Maximum Gross Weight* | 171,870 lbs | (77,960 kg) |

*Maximum permissible gross vehicle weight with options, attachments, full fuel tank and payload.

| WEIGHT DISTRIBUTION | Front Axle | Rear Axle |
|---------------------|------------|-----------|
| Empty | 48% | 52% |
| Loaded | 34% | 66% |

Rigid Haul Truck TR45

TR45 Performance Data (Graphs Based On 0% Rolling Resistance)

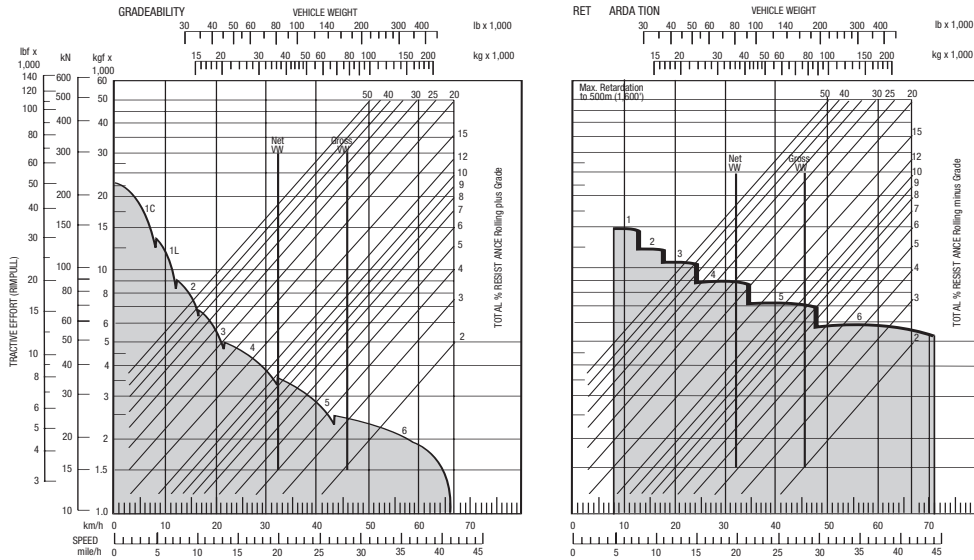

Dimensions

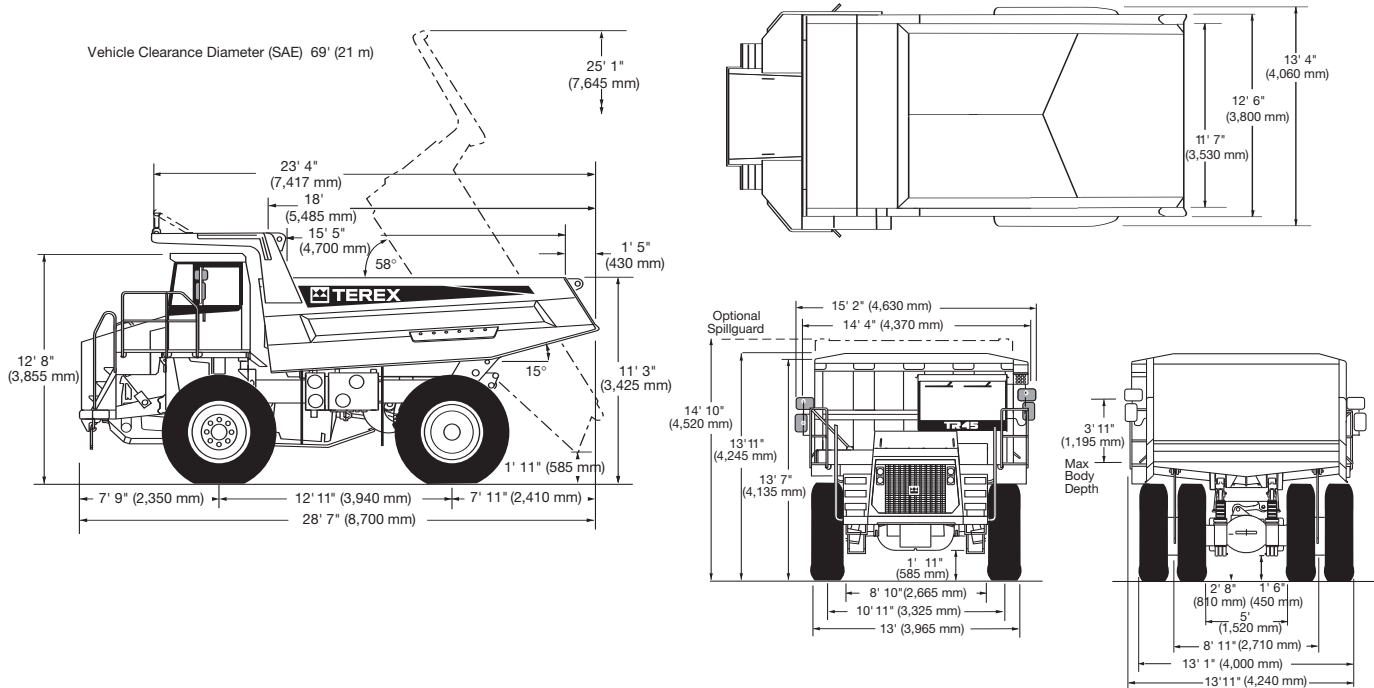

Terex Construction Americas

8800 Rostin Road
Southaven, MS 38671
USA

TEL 662-393-1800
SALES 866-837-3923
PARTS & TECH SUPPORT 888-201-6008
FAX 662-393-1700
EMAIL sales@terexca.com
WEB terexca.com

For more information, product demonstration, or details on purchase, lease and rental plans, please contact your local Terex Distributor.

Effective date: August 15, 2006. For further information, please contact your local distributor or the Terex sales office listed. Product specifications are subject to change without notice or obligation. The photographs and drawings in this brochure are for illustrative purposes only. Refer to the appropriate Operator's Manual for instructions on the proper use of this equipment. Failure to follow the appropriate Operator's Manual when using our equipment or to otherwise act irresponsibly may result in serious injury or death. Prices and specifications subject to change without notice. The only warranty applicable is the standard written warranty applicable to the particular product and sale. Terex makes no other warranty, expressed or implied. Products and services listed may be trademarks, service marks or trade-names of Terex Corporation and/or its subsidiaries in the USA and other countries and all rights are reserved. *Terex* is a Registered Trademark of Terex Corporation in the USA and many other countries. Copyright ©2007 Terex Corporation