

HCB SERIES Crushing Buckets





The Hydraram crushing bucket is specifically for breaking concrete and bricks at the jobsite, and is the first of its kind on the market.

There are numerous applications possible: demolition and construction work in general, remediation of industrial and urban waste, processing materials from quarries, the earthmoving sector, road works, mining, environmental remediation, crushing rocks.

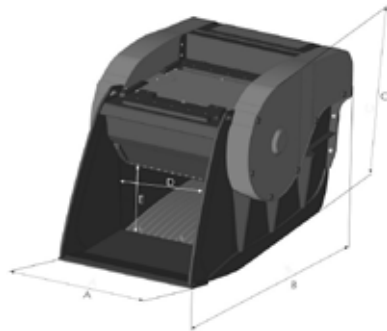
The crushing buckets are made from the most durable HARDOX-400® steel with an extremely high wear resistance, minimum maintenance and a long lifespan.

Easily replaceable wear parts



CRUSHING BUCKETS			HCB-16	HCB-26	HCB-32	HCB-42	HCB-56
	Excavator class ¹	t	14 - 22	22 - 32	28 - 38	36 - 50	40 - 65
	Weight*	kg	1720	2380	3310	4280	5570
	Working pressure	bar	270	300	300	300	300
	Oilflow	l/min	90 - 100	130 - 140	130 - 140	170 - 180	250 - 300
A	-	mm	740	900	1030	1100	1390
B	-	mm	1800	2050	2050	2150	2250
C	-	mm	1100	1330	1330	1400	1450
D	-	mm	600	700	820	900	1200
E	-	mm	450	500	500	500	550
	Capacity	ltr	200	200	300	400	500

¹ Recommended excavator / attachment combination

* The above mentioned weight is without connection plate

